

Foster

On-A-Roll Lifter®

Instruction Manual for Grande Model # 61590, Grande Plus Model # 61591 & Grande Max Model # 61594

Read Before Use!

Important instructional, safety and precautionary information!

It is the user's responsibility to exercise good judgment, common sense, safety measures and reasonable limits regarding the use of the On-A-Roll Lifter® so as not to incur risk to the user or damage to the materials being carried. In order to obtain maximum benefit from your machine, please read these instructions carefully before using the On-A-Roll Lifter®.

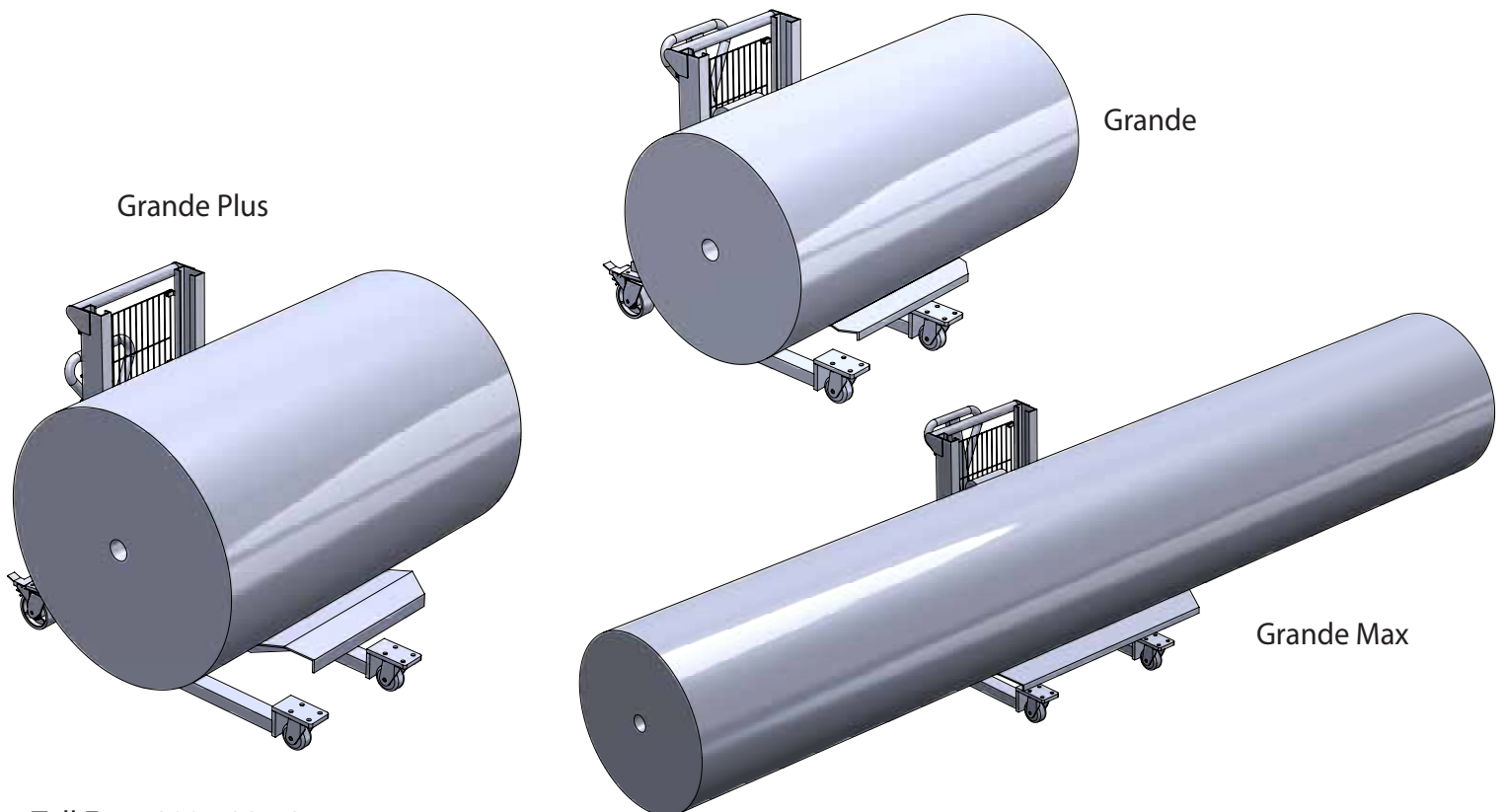

Toll Free: 800-523-4855
information@go-foster.com

204 B Progress Drive, Montgomeryville, PA



spiralbinding.com
800-631-3572

Contents

1. Warnings & Safety Rules

- 1.1 Warnings
- 1.2 Caution
- 1.3 Safety Rules

2. Daily Inspection

- 2.1 What to check before operation

3. Operation

- 3.1 How to use the brakes
- 3.2 Loading & unloading the roll on the tray
- 3.3 Lifting the tray
- 3.4 Lowering the tray
- 3.5 Maneuvering with heavy rolls

4. Maintenance

- 4.1 Lubrication Points

5. Technical Data

- 5.1 Technical Specifications Grande
- 5.2 Technical Specifications Grande Plus
- 5.3 Technical Specifications Grande Max

6. Warranties

Warnings & Safety Rules

1.1 Warnings

1. Do not put your hands or feet under the load tray.
2. All unconcerned personnel should be more than 60 cm away from the unit while the rolls are in transit, or being lifted.
3. Do not move the unit while a load is being raised.
4. Do not move the unit without securing the rolls with the straps.
5. Do not move the unit with tray raised more than a couple inches to avoid tip overs and vision obstruction.
6. Do not operate the lifter if the straps are frayed or damaged.
7. Do not put your foot in front of the swivel wheel; injury could occur when the load is lowered.
8. Do not operate the machine beyond its rated capacities, or outside of the machines' normal operation.
9. Do not operate the media lifter on uneven surfaces.
10. Do not lift persons. People could fall and suffer severe injury.

1.2 Caution

1. Operators should read and understand the instructions before using the On-A-Roll Lifter® to avoid injury.
2. The On-A-Roll Lifter® is used to lift or lower rolls of media (e.g. paper rolls) within specified capacity and should not be used for other functions.
3. Do not operate unless you have been trained or authorized to do so.
4. Do not lower the load at fast speed, as it creates unsafe conditions.
5. Care should be given to the balance and orientation of loads. Unbalanced or shifting loads can cause danger to the operator or bystanders. If the load becomes unstable, stop work immediately.
6. The weight of the roll should be distributed evenly on the load tray. The center of gravity of the goods should be in the center of the load tray width.
7. Do not modify or repair the unit without written consent from the manufacturer.
8. Remove the loaded goods from the lifter and use safety breaks to prevent the lifer from moving when servicing it.
9. This lifter is not designed to be water resistant. If not in use, please store in dry conditions and lower the load tray to the lowest position for stability.

Warnings & Safety Rules

1.3 Safety Rules

Failure to obey the instructions and safety rules in this document may result in serious injury.

1. **Do not operate unless you:**

a) Understand and practice the principles of safe machine operation specified in this manual:

- Avoid hazardous situations
- Always perform a pre-operation inspection
- Always perform the function tests (see step 2.1) prior to use
- Inspect the workplace

b) Read, understand and obey:

- Manufacturer's instructions and safety rules
- Employer's safety rules and worksite regulations
- Applicable governmental regulations

2. **To avoid hazardous situations:**

- Do not overload the lifter
- Make sure media roll is balanced on the Load Tray and steady
- The media roll is secured with two straps
- Do not raise the load unless the machine is on a firm, level surface
- Do not move the lifter with the raised load, except for minor positioning
- Do not tilt the lifter back with raised load
- Do not operate the lifter in strong and gusty winds
- Prior to use, inspect the work area for drop-offs, holes, bumps, debris, unstable surfaces or other possible hazardous conditions
- Do not subject the lifter to horizontal force by raising or lowering a fixed or overhanging load
- The lifter can only be used in a lighted environment at least 50LUX

3. **Collision Hazards:**

- Do not lift the load if not properly centered on the Load Tray
- Check the work area for overhead obstruction or other possible hazards
- Do not stand under or allow personnel under the lifter when the load is raised
- Do not lower the load unless the area below is clear of personnel and obstructions

Warnings & Safety Rules

1.3 Safety Rules

4. **Bodily Injury Hazards:**
 - Keep hands and fingers away from chain, wheels and other potential pinch points
 - Recommend operators wear safety shoes and gloves
 - Do not put your feet under the load tray

5. **Improper Use Hazard:**
 - Never leave a machine unattended with the load. Unauthorized personnel may attempt to operate the machine without proper instruction, creating an unsafe situation.

6. **Damaged Machine Hazards:**
 - Do not use a damaged or malfunctioning machine
 - Be sure all the decals are in place and visible
 - Maintain proper lubrication of the chain

7. **Other Items:**
 - When turning and pushing the machine on rough flooring, more effort will be required
 - Keep rolls centered to avoid them tipping to the side
 - When working on sloped surfaces, secure straps around media to avoid movement of rolls toward the rear of the lifter

Failure to obey the instructions and safety rules in this document may result in serious injury.

Daily Inspection

2.1 What to check before operation

It is the operator's responsibility to make sure that the On-A-Roll Lifter® is inspected daily to ensure safe operation:

Check the On-A-Roll Lifter® before operation:

1. Inspect the vertical guide rails, load tray, carriage and hydraulic components for damage, including bending, cracking and loose or missing hardware. Do not use the On-A-Roll Lifter® if any faults are discovered during your visual inspection.
2. Inspect the hydraulic system and nearby surfaces for evidence of leaks. Discontinue use if leaking is evident.
3. Inspect the (4) caster wheels for damage and smooth operation. Wheels should rotate and swivel smoothly, and should not be cracked, chipped or broken. Do not use if wheels are damaged or broken.
4. Check the function of the brake. Ensure the parking brakes on the rear casters are working properly.
5. Ensure all hardware is present and fitted correctly. Inspect/tighten any loose fasteners or hardware.

Caution: Do not use the unit if any malfunction or fault is found.

Operation

3.1 How to use the brakes

The Lifter is equipped with 2 brakes.

1. To engage the brake, press the "ON" tab down with your foot until it locks into place.
2. To release the brake, press the "OFF" tab down with your foot.

Lock shown on the
Caster Wheel in the
lock position.

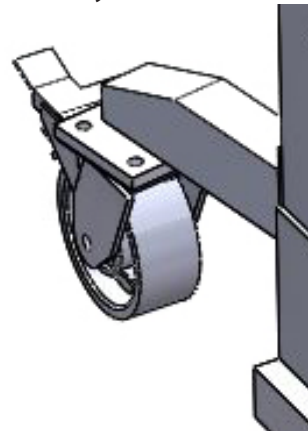
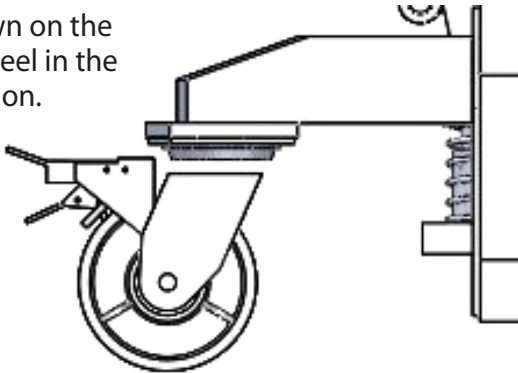

Lock shown on the
Caster Wheel in the
unlock position.

3.2 Loading & unloading the roll on the tray

Loading

1. Make sure the brakes are applied.
2. Position the On-A-Roll Lifter® and carefully use a fork lift to place the roll onto the tray. Make sure the roll is properly centered on the tray.

Unloading

1. Make sure the brakes are applied.
2. Position the On-A-Roll Lifter® and carefully use a fork lift to remove the roll off of the tray.

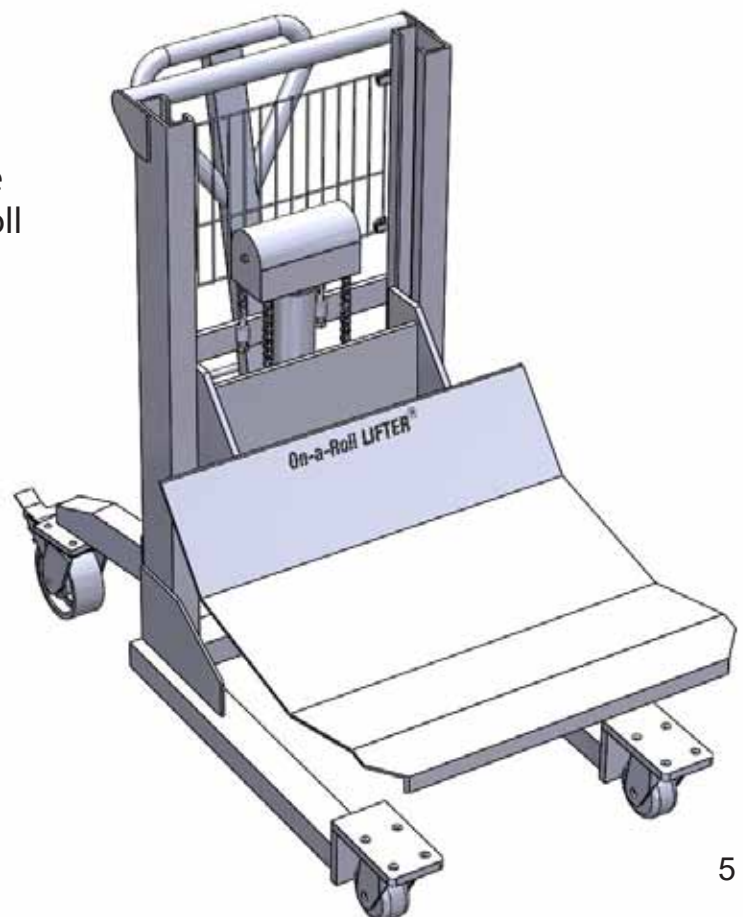

Operation

3.3 Lifting the tray

Warning: Do not overload the load tray. The load must be evenly distributed on the Load Tray surface so that it does not tilt forward or sideways. The parking brakes should be engaged whenever the On-A-Roll Lifter® is being loaded or unloaded.

1. To raise the load tray, push the release lever down.
2. Pump the handle up and down or pump the lift pedal with your foot.
3. Press the lift pedal or hand pump until the load tray reaches the desired height. The load tray can be raised up to 865 mm (34") for precise unloading.

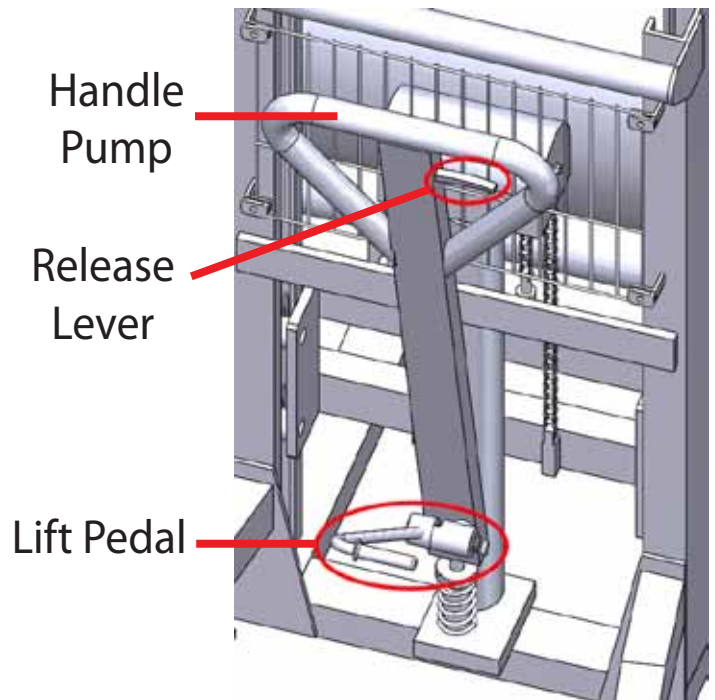

3.4 Lowering the tray

Warning: do not put any part of the body under the Load Tray. The parking brakes should be engaged whenever the On-A-Roll Lifter® is being loaded or unloaded.

1. To lower the load tray, stand behind the On-A-Roll Lifter®.
2. Find the release lever and lower the load tray by pulling the release lever past the neutral position.
3. Do not open lower too quickly, as this creates a dangerous work environment.

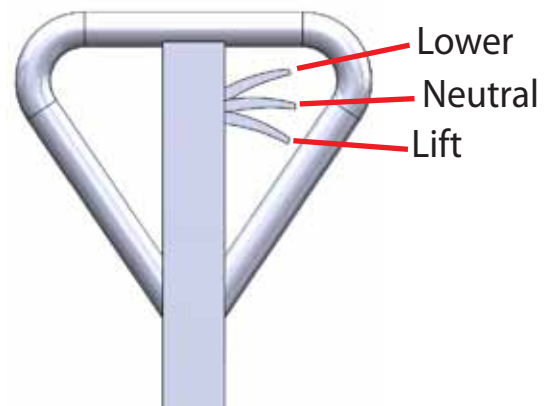

3.5 Maneuvering with heavy rolls

1. To adjust the direction of the wheels and ensure smooth rolling action on heavy loads, exert force on the handle.

Maintenance

4.1 Lubrication Points

1. Lubricate with grease each point described below each month:
 - a) Axle and bearing wheels
 - b) Chain guide roller on cylinder
 - c) Connecting chain assembly

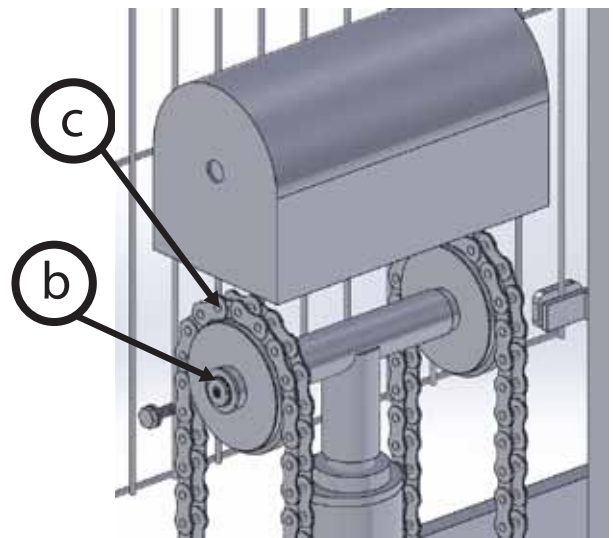
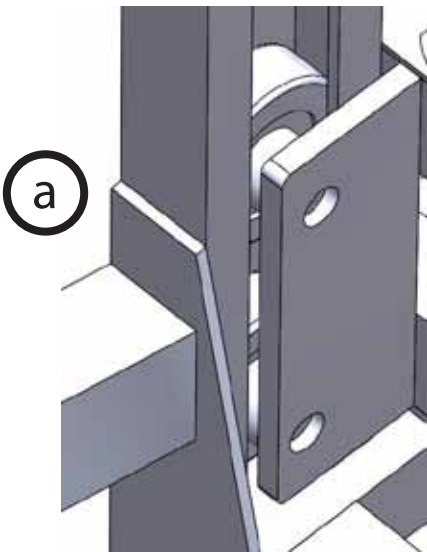

Remove screw to access the chain guide.

2. Change hydraulic oil every 12 months.

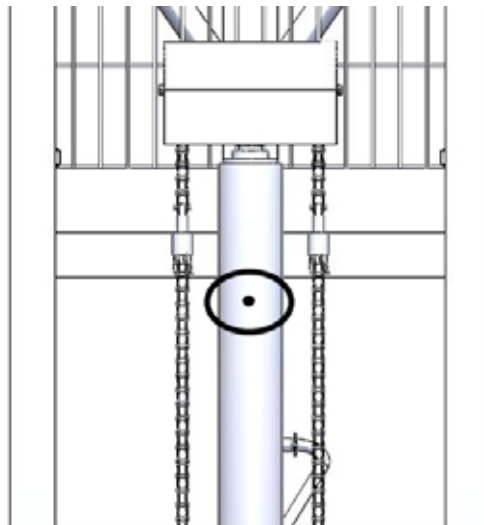

Technical Data

5.1 Technical specifications: Grande

Specifications	LIFTER ITEM # 61590
Roll Weight Capacity	1540 lbs (700 kg)
Max. Roll Width	61" (1550 mm)
Max. Roll Diameter	31.49" (800 mm)
Oil	Use L-HM68 Hydraulic oil (equivalent to ISO VG68) if temperature is between 5°F - 23°F (-15°C - -5°C). Use L-HM46 Hydraulic oil (equivalent to ISO VG46) if temperature is between 23°F - 113°F (-5°C - 43°C).

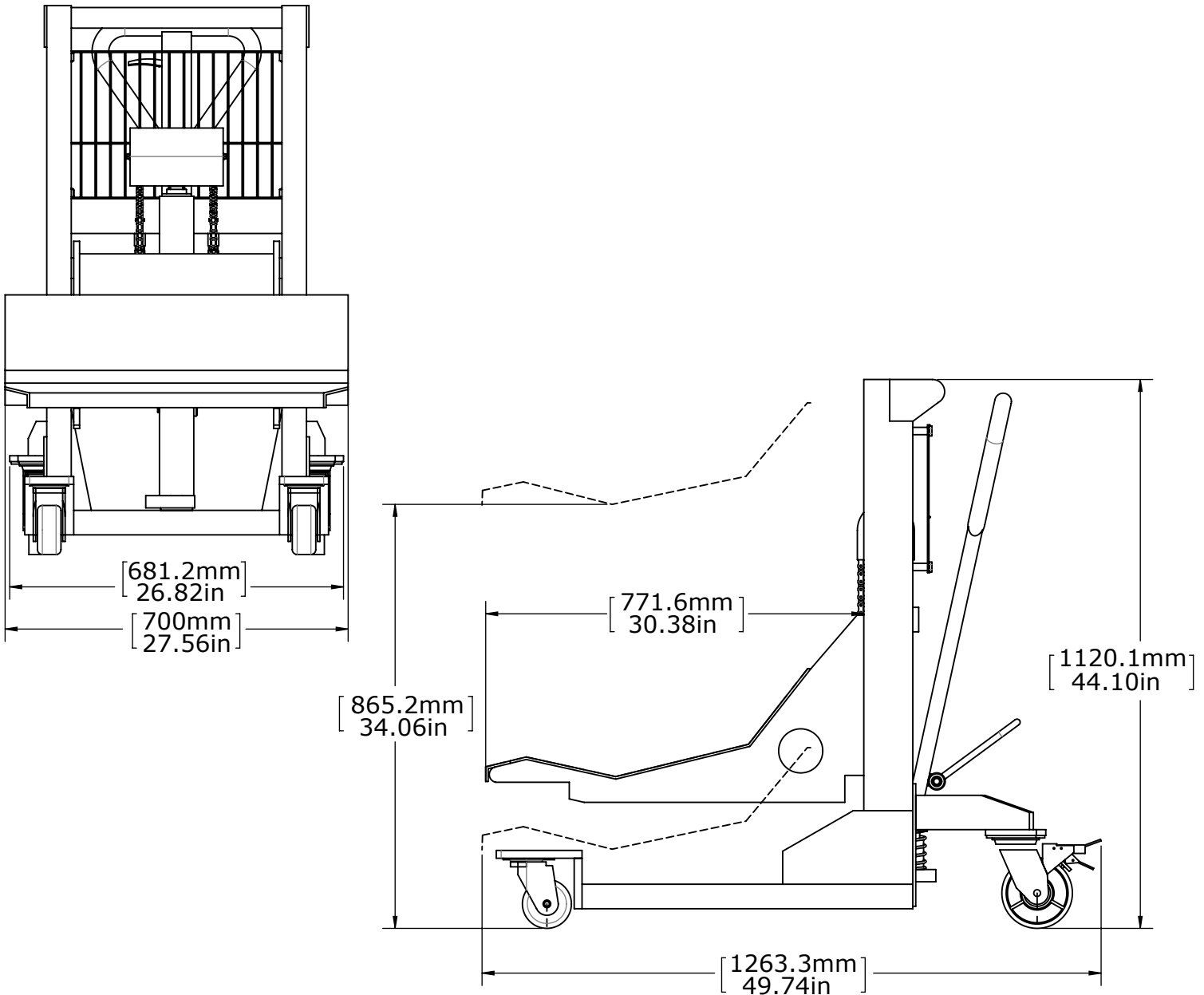

Technical Data

5.2 Technical specifications: Grande Plus

Specifications	LIFTER ITEM # 61591
Roll Weight Capacity	2000 lbs (907 kg)
Max. Roll Width	61" (1550 mm)
Max. Roll Diameter	39" (990 mm)
Oil	Use L-HM68 Hydraulic oil (equivalent to ISO VG68) if temperature is between 5°F - 23°F (-15°C - -5°C). Use L-HM46 Hydraulic oil (equivalent to ISO VG46) if temperature is between 23°F - 113°F (-5°C - 43°C).

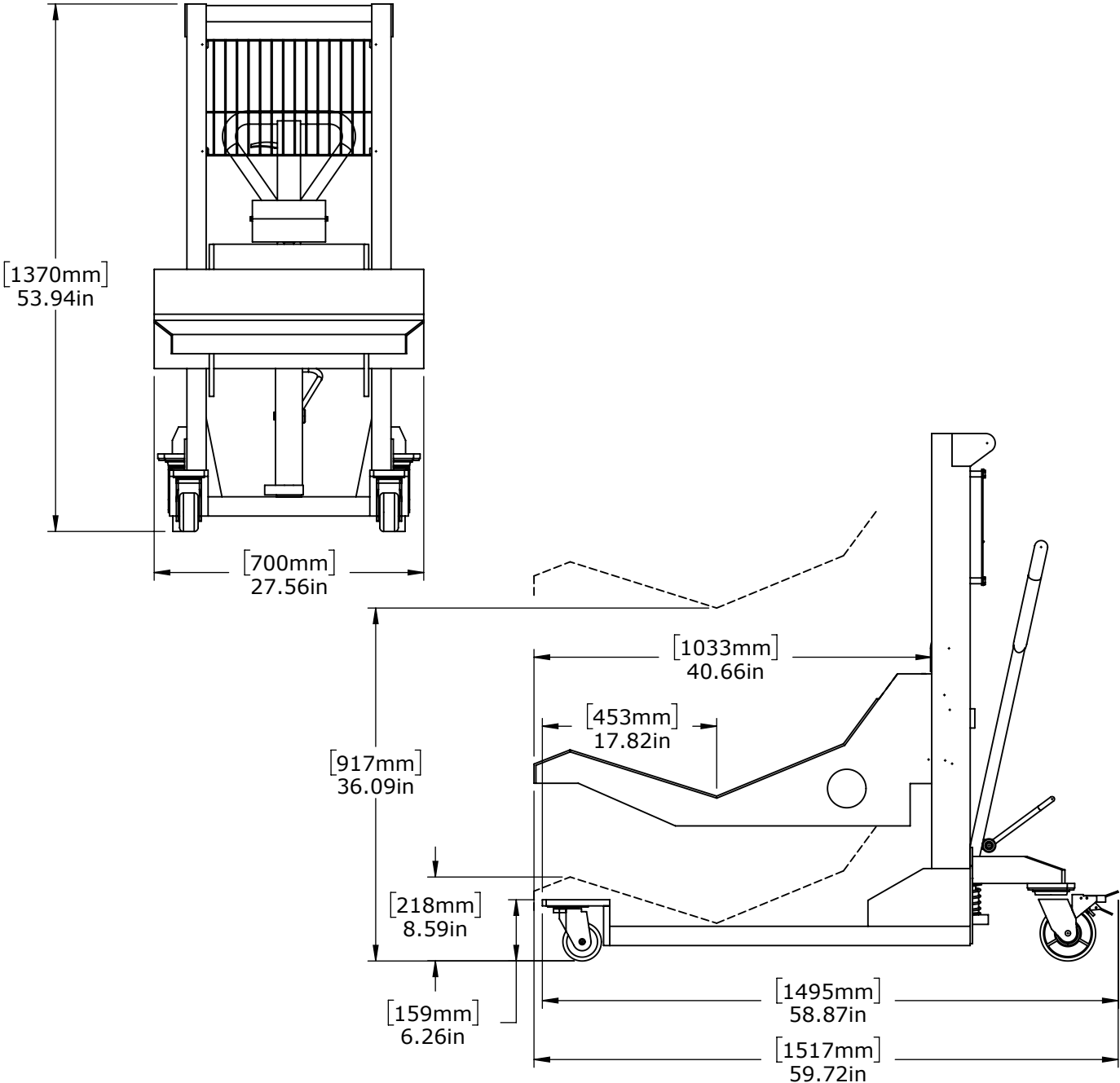

Technical Data

5.3 Technical specifications: Grande Max

Specifications	LIFTER ITEM # 61594
Roll Weight Capacity	2200 lbs (1000 kg)
Max. Roll Width	16' 5" (5 m)
Max. Roll Diameter	31.49" (800 mm)
Oil	Use L-HM46 Hydraulic oil (equivalent to ISO VG46)

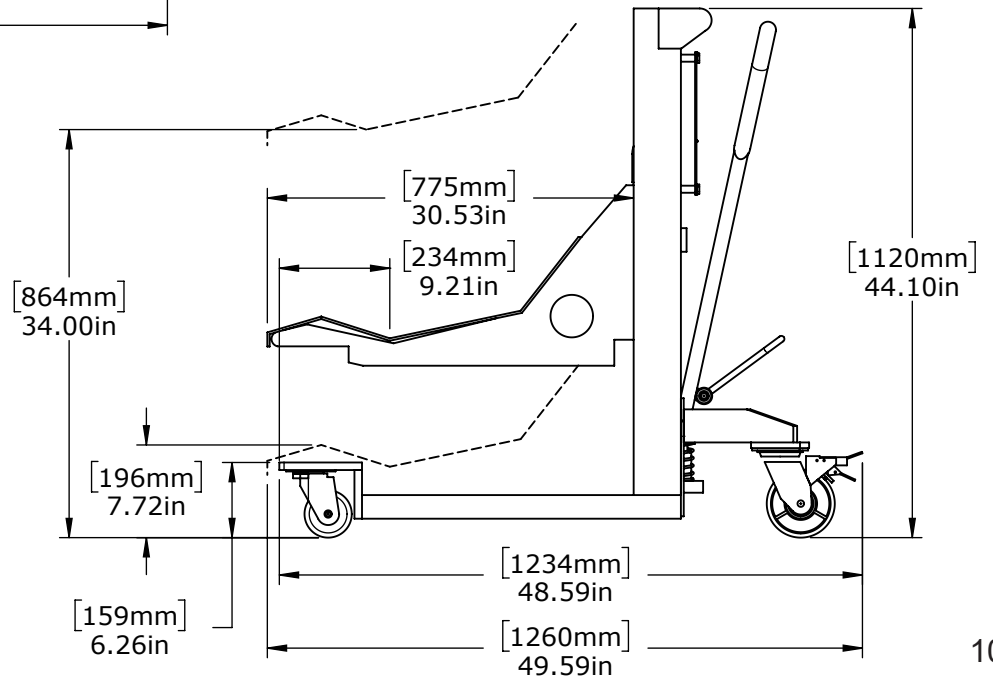
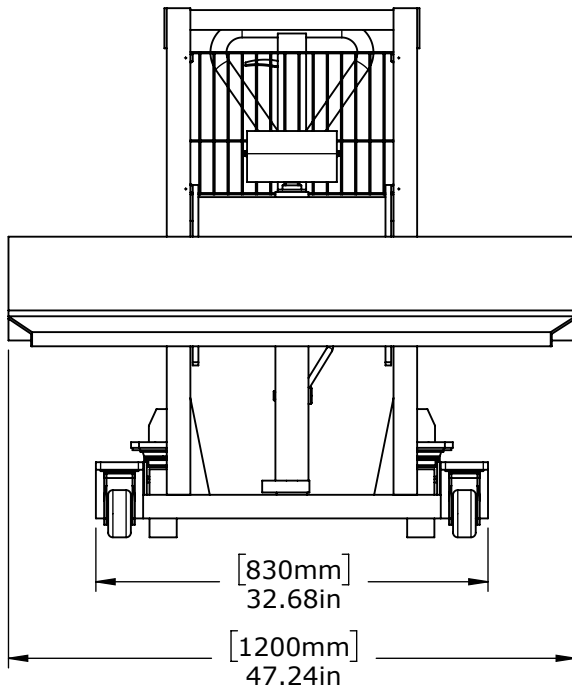

Warranties

6 Warranties

1. 2- year warranty on all wheels, hydraulics and media tray

All Foster products are inspected before shipment and believed to be free from defects in workmanship. Foster cannot be responsible for tools that show excessive wear or damage resulting from misuse, accidents or abuse.

These warranties do not cover any product that has been altered, modified or damaged, neglected, accidentally dropped or improperly used. If any of the previous occurs, the warranty shall be considered null and void.