



HP Latex 2700 / FS Series Jumbo Dual Roll Kit Series User Guide

SUMMARY

How to use your product.

About this edition

© Copyright 2024 HP Development Company, L.P.

Edition 3, November 2024

Legal notices

The information contained herein is subject to change without notice.

The only warranties for HP products and services are set forth in the express warranty statement accompanying such products and services. Nothing herein should be construed as constituting an additional warranty. HP shall not be liable for technical or editorial errors or omissions contained herein.

Table of contents

1 Introduction	1
2 Dual-roll split-spindles central support	2
Assemble the central supports.....	2
3 Load rolls onto the split spindles	3
Roll-loading procedure.....	3
4 Load a roll (roll-to-roll configuration)	5
Load a roll.....	6
Manual loading	7
5 Maintain the central support	9
Clean and lubricate the central-support bearings.....	9
6 Dual-roll spindle specifications	10

1 Introduction

This guide describes the installation and use of the HP Latex 2700/FS Series Jumbo Dual Roll Kit Series.

With this accessory installed in the HP Latex 2700/FS, the printer can print dual-roll applications with large rolls of substrate:

- Maximum roll width: 2 × 1.52 m (2 × 60 in)
- Maximum roll diameter: 400 mm (15.75 in)
- Maximum total weight of both rolls: 2 × 200 kg (2 × 440 lb)

Dual-roll split spindles and quick coupling for input and output central support make it easier to load large rolls of substrate; quicker and safer with one printer operator.

To use dual-roll applications you must install the HP Latex 2700/FS Series Jumbo Dual Roll Kit. The following items are included in the box:

- Four semi-spindles
- Substrate-input central support
- Substrate-output central support
- Two anchor kits
- Four extra feet
- Plain diverter
- Two plain diverter supports
- Two plain diverter support shims

For further information on using your printer, see the appropriate user guide or maintenance and troubleshooting guide.

2 Dual-roll split-spindles central support

The following sections provide details for this topic.

 **DANGER!** Risk of trapped fingers.

Assemble the central supports

The following steps provide the complete procedure for this topic.

You can print on two rolls at the same time by using the dual-roll split spindle. See the installation guide to check the installation of the central-support split-spindle assembly.

 **IMPORTANT:** Two dual-roll central supports are provided. The one with a "I" label is for the input side of the printer and the other with a "O" label is for the output side. You have to follow the same process in order to install input and output side central supports onto the corresponding base.

To assemble the central-support split spindles to its base, insert the central-support foot on the base guides and move it to the end by pushing the handle. Make sure that the base hook is fixed.

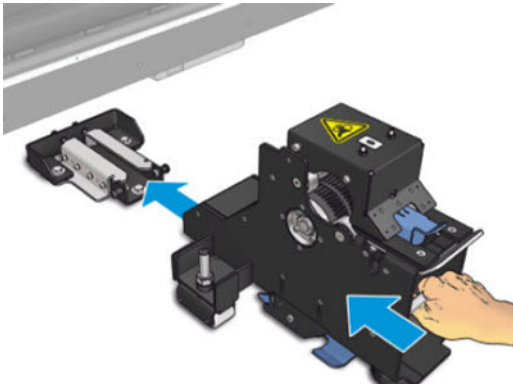

If you want to remove the central support, raise the blue lever with a hand, and firmly pull the central support to remove it from its base.

3 Load rolls onto the split spindles

Follow this procedure to load the rolls.

Roll-loading procedure

The following steps provide the complete procedure for this topic.



 **NOTE:** This video applies to HP Latex 3500/3600 series, as well as the HP Latex 2700/FS series printers.

1. Insert the first roll on one of the split spindles.
2. Insert the second roll on the other split spindle.
3. Load the split spindles in the printer.

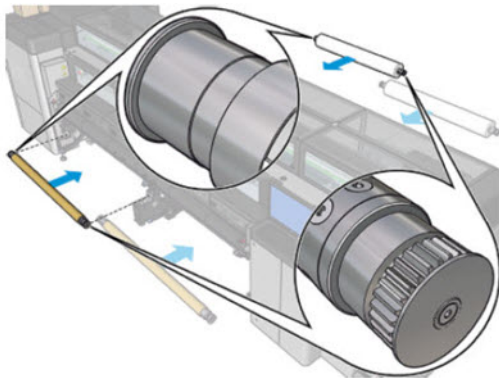

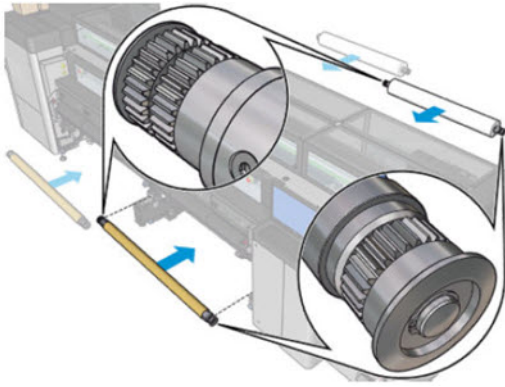

4. Move the rolls to the center of the printer. Accurately position each roll following one of the spindle marks. The input and output rolls should be positioned identically on their respective parts of the spindle.

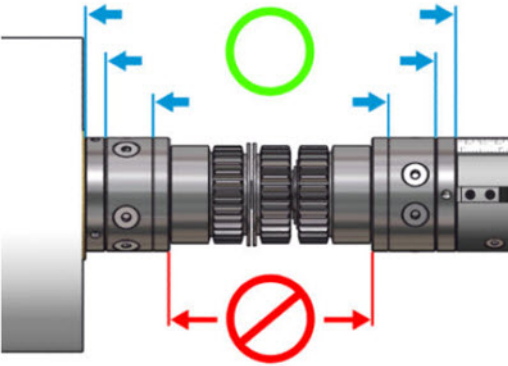

5. Inflate the valves at both ends by connecting the air gun to the pneumatic connectors.

TIP: Before inflating, use the pneumatic gun to blow air around the valve area to remove any dirt.

WARNING! The air gun provided with the printer is only intended to inflate the spindle. When recommended to use for cleaning purposes, make sure to do so according to local regulations since additional safety provisions may apply.

Table 3-1 Dual-roll split-spindle specifications

Characteristic	Specification
Minimum roll width	635 mm (25 in)
Maximum roll width	2 × 1.52 m (2 × 60 in)
Minimum gap between rolls	134 mm (5.3 in)
Maximum roll diameter	400 mm (15.75 in)
Maximum total weight of both rolls	2 × 200 kg (2 × 440 lb)

4 Load a roll (roll-to-roll configuration)

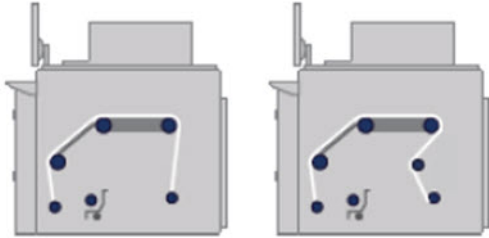

The two substrate rolls are mounted on the rear dual-roll spindle and will be collected on the front dual-roll spindle. The substrate goes from the input spindle over the main roller, over the platen, over the front diverters and then to the output spindle.

 **NOTE:** When using dual rolls, you are recommended to use the roll-to-roll configuration for the best performance.

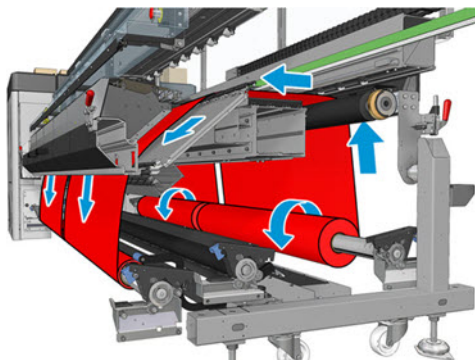

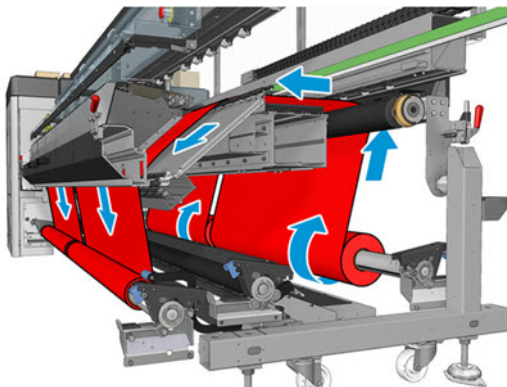

You can load substrate with the printed face inwards or outwards on the spindle, in which case the spindle will turn in the opposite direction. The printer asks you for the winding direction if it cannot detect it automatically.

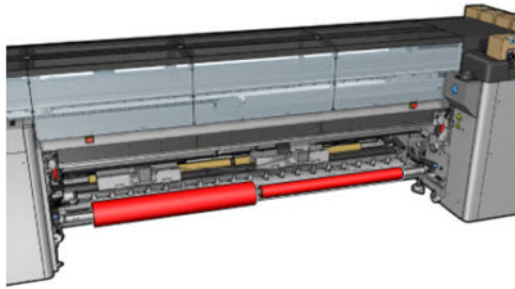

Before loading two rolls into the printer, you must have both rolls loaded on the rear dual-roll spindle and two empty cores loaded on the front dual-roll spindle.

If the rolls are of unequal lengths, the longer roll should be on the right as seen from the front of the printer; on the left as seen from the rear. That way, when the shorter rolls runs out, you can continue printing on the other roll.



 **NOTE:** When one roll runs out, you should lock the differential in the middle of the spindle, using the lever on the left-hand side.

Load a roll

In order to use the dual-roll kit, it must be installed first.

1. Go to the Internal Print Server and select **Substrate Load/Unload**, then select the correct configuration.
2. In the Internal Print Server, choose from the list of substrate types the type that you have loaded.
3. If they are installed, remove the substrate edge holders from the print platen so that they do not get in the way while loading the substrate.

 **CAUTION:** Loading the substrate on top of the edge holders could severely damage the printheads and carriage.

4. You may find it helpful to lock the differentials on the input and output spindles while loading.

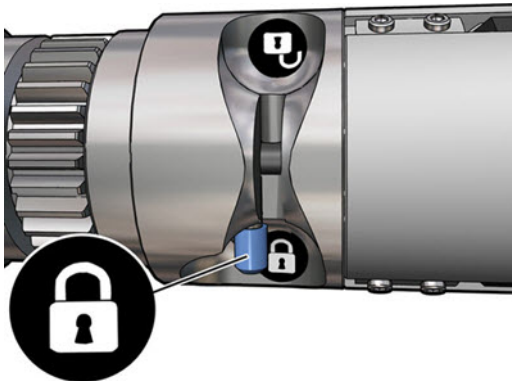

5. Rest the ends of the spindle on the platforms provided at the rear of the printer; plastic pads are provided to absorb the impacts.
6. In the same way, load the spindle with the empty core into the front of the printer. In this case, the geared end of the spindle should be on the right.

Manual loading

The following steps provide the complete procedure for this topic.

 **NOTE:** Assisted loading is not recommended in a dual-roll configuration.

1. Use the Internal Print Server to raise the carriage beam to its loading position, or use the physical button.
2. Open the front door and the curing module.
3. Open the loading table.
4. Unlock the differential in the input spindle.
5. Unwind a length of substrate from the first input roll and place it in the print zone.
6. Push the substrate from the first roll through the printer until it reaches the output spindle.
7. Unwind a length of substrate from the second input roll and place it in the print zone.
8. Push the substrate from the second roll through the printer until it reaches the output spindle.
9. Align the substrate by checking that the substrate edge is in the same position on the input and output spindles. This can be done by using the rulers on the spindles or by measuring the distance between the right edge and the side plate.

 **NOTE:** You are recommended to align the edges of both rolls by the lines on both sides of the spindle's center mark.

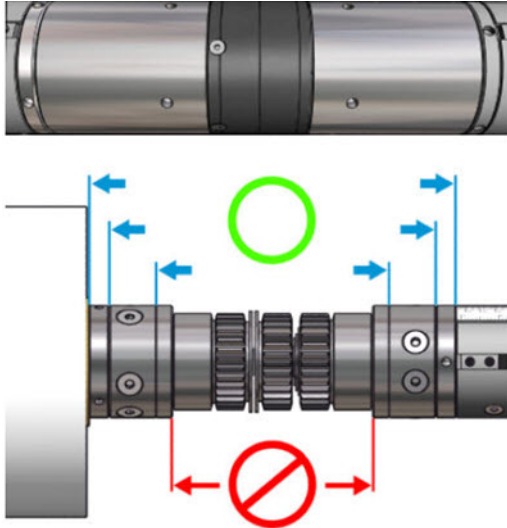

 **NOTE:** The substrate-advance sensor must be covered by the substrate.

10. When the substrate is evenly tensioned and flat (no wrinkles or bumps, attach it to each empty core with adhesive tape. Tape it first in the center, and then at the left and right sides, making sure not to pull the substrate excessively or leave it wrinkled.

11. If you are using them, place the four substrate edge holders into position and attach them at the front.

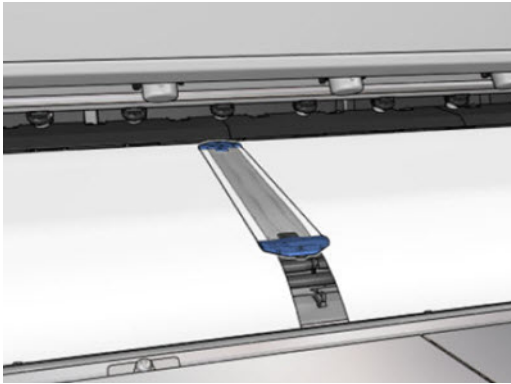

12. Close the front door and the curing module.
13. If you are using them, attach the substrate edge holders.
14. Close the loading table.
15. Ensure that the spindle differentials are unlocked.
16. Use the Internal Print Server to lower the carriage beam to its printing position.
17. Go to the Internal Print Server and tap the **Finish** button. The printer rotates the rolls to check their diameters, and it also checks the width of the roll, the winding direction, the vacuum, and the substrate-advance calibration (this takes about a minute).



NOTE: Some substrates (such as transparent substrates) cannot be measured by the printer in this way. In such cases, you will be asked to enter the Left Edge and Width fields yourself into the Internal Print Server. Use the ruler on the spindle to check these values.

The printer is now ready to print.

5 Maintain the central support

The central support requires some maintenance at every 50,000 printed substrate meters.

Clean and lubricate the central-support bearings

HP recommends wearing gloves and glasses throughout this procedure.

1. Go to the Internal Print Server and select **Substrate unload**.
2. Remove the spindles from the printer.
3. Open the central-support latch and clean the four bearings using the air gun. Keep the bearings clean from dust and small metallic shavings.

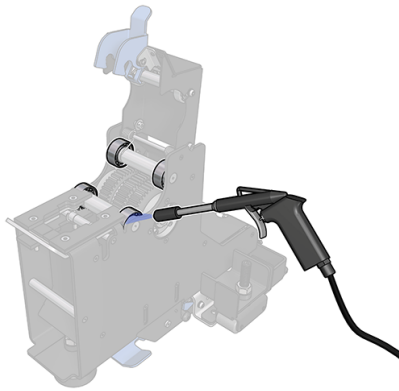

4. Lubricate the four bearings using a multi-purpose lubricant spray to protect them from rust and corrosion.

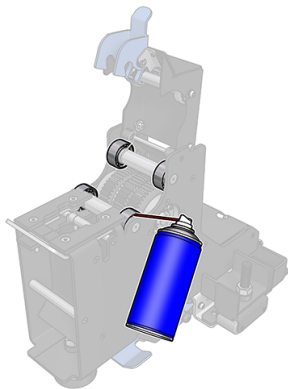

6 Dual-roll spindle specifications

This topic provides a full set of reference information for this subject.

Table 6-1 Dual-roll spindle specifications

Characteristic	Specification
Minimum roll width	635 mm (25 in)
Maximum roll width	2 × 1.52 m (2 × 60 in)
Minimum gap between rolls	134 mm (5.3 in)
Maximum roll diameter	400 mm (15.75 in)
Maximum total weight of both rolls	2 × 200 kg (2 × 440 lb)